



TYPE: T24-ACM-SAf



T24-ACM-SAf High Speed Single Channel Telemetry Docking Module

Description

The T24-ACM-SAf is a single channel connectivity module for high speed applications, offering high precision measurement of a single input. It provides measurements at 2000 samples per second, and provides 5V excitation to drive transducer loads down to 85ohms. The T24-ACM-SAf will usually be used in conjunction with an analogue output module or for supplying data to a computer via a base station.

Usable around the globe on the licence-free 2.4GHz frequency, the T24 range avoids local radio interference to ensure data integrity and security. The system provides exceptional performance in the field by 'powering down' between transmissions or 'powering off' completely.

Featuring a compartment for a pair of alkaline 'D' cells, the T24-ACM-SAf also has a regulator circuitry for an external power supply. The batteries can also be used to provide power in case of external supply failure. For easy wireless sensing, the unit provides connections via the 2 part screw terminals and environmental sealing to IP67.

The T24-ACM-SAf high accuracy, low noise measurement electronics deliver high resolution, low drift results which can be user calibrated over 9 points to enable linearization and to deliver results in user definable engineering units.

The wireless sensor transmitter is configured and calibrated (either by applying known inputs or by table entry) using free T24 Toolkit software which runs on a PC connected to a T24 base station.

The T24 offers a wireless range of up to 800 m (2,600 ft) in open field site.

For use in any measuring application, from torque to weight, vibration to flow, the T24-ACM-SAf offers users a complete solution.

Specification

Strain gauge system	4 wire
Strain gauge excitation	5Vdc
Strain gauge resistance (min)	85Ω
Strain gauge sensitivity (max)	3.1 mV/V
Offset temperature stability (max)	4 ppm/°C
Gain temperature stability (max)	5 ppm/°C
Non linearity before linearization (max)	25 ppm of FR
Internal resolution/Bits	16,000,000/24
Noise free resolution/Bits at 2Khz per second	8,000/13
Transmission rate	2000Hz
Battery supply voltage	2.1Vdc to 3.6Vdc (3Vdc typical)
External power supply voltage	5-18Vdc or 2 x D cell
Battery life (constantly on)	5.5 days
Battery life (12 sessions per day of 5 mins)	4.5 months
Radio type/frequency	Licence exempt, 2.4GHz
Radio transmission range	800m
IP rating	IP67
Operating temperature	-20 to +55°C
Storage temperature	-40 to +85°C
Humidity	0 - 95%RH
Case dimensions	164 x 84 x 57mm
Case material	ABS
Terminals	2.5mm rising clamp field terminals
Cable size	Ø4 to 8mm
Accessibility	All electronics accessible by removing lid

Features

- Measurements at 2 KHz
- Screw terminals for ease of connection
- Internal batteries (2 x D) or external power
- Exceptionally low power for long battery life
- Simple configuration of acquisition module via PC using a base station and telemetry toolkit software
- Integrated PCB antenna
- Remote power 'on' and 'off'
- IP67 sealed enclosure

Typical Applications

- Crane weighing and overload protection
- Anchor load monitoring
- Silo weighing
- Vehicle weighing

SCIENCE GATE
Your Automation Partner



SCIGATE AUTOMATION (S) PTE LTD

No 1 Bukit Batok Street 22 #01-01 Singapore 659592
Tel: (65) 6561 0488 Fax: (65) 6561 0588
Email: sales@scigate.com.sg Web: https://scigate.com.sg/

Business Hours: Monday - Friday 8:30AM - 6:15PM

OLCM SYSTEMS
Solutions in Load Cell Technology

T24-ACM-SAf High Speed Single Channel Telemetry Docking Module

Dimensions

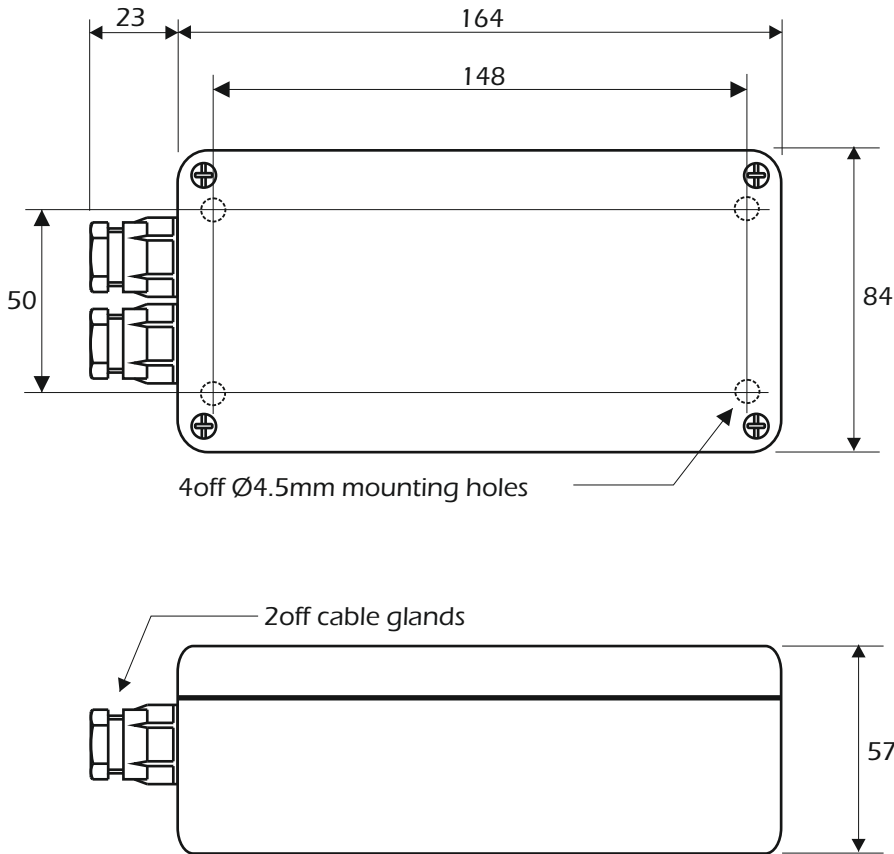

All dimensions are in mm



www.lcmsystems.com

LCM Systems Ltd

Unit 15, Newport Business Park, Barry Way
Newport, Isle of Wight PO30 5GY UK
Tel: +44 (0)1983 249264
sales@lcmsystems.com
www.lcmsystems.com

LCM Systems (România)

Strada Ștefan Cel Mare 26a,
Tunari, cod.077180, Ilfov, România
Tel: +40 (0)77 4641899
ro@lcmsystems.com
www.lcmsystems.ro

Due to continual product development, LCM Systems Ltd reserves the right to alter product specifications without prior notice.

Issue No. 1

Issue date: 03/10/2019
APPROVED
(unapproved if printed)